

Document Title Technical Specification		Document ID 1624B_TLS	Version 0.4	Date 10.02.16
Project Designation & Project Name 1624B	Product CC1150 Battery	Customer Various		Page 1 / 23

**CC1150 BATTERY**  
**TECHNICAL SPECIFICATION**

Document Status  
**RELEASED**

Document Approval				
Stage	Position	Name	Initials	Date
Author	Commercial & Engineering Support Manager	G. Hancox	<i>GH</i>	22/04/16
Reviewed	Electronics Engineering Manager	A Robinson	<i>AR</i>	22/4/16
	Mechanical Engineering Manager	D. Asplin	<i>DA</i>	22-4-16
	Project Manager	P. Heyes	<i>PH</i>	22-4-16
	Technical Marketing Manager	N. Oliver	<i>NO</i>	22-4-16
Approved	Operations Director	M. Allen	<i>MA</i>	22.4.16

**Statement of Confidentiality**

The information contained within this document is confidential and proprietary to Accutronics Limited. This information should not, in whole or in part, be reproduced or used except as expressly and duly authorised by Accutronics Limited.

Document Title		Document ID	Version	Date
Technical Specification		1624B_TLS	0.4	10.02.16
Project Designation	Product	Customer		Page
1624B	CC1150 Battery	Various		2 / 23

## 1 CONTENTS

<b>1</b>	<b>CONTENTS</b> .....	<b>2</b>
<b>2</b>	<b>INDEX OF FIGURES</b> .....	<b>3</b>
<b>3</b>	<b>INDEX OF TABLES</b> .....	<b>3</b>
<b>4</b>	<b>REVISIONS</b> .....	<b>4</b>
<b>5</b>	<b>PROJECT &amp; DOCUMENT</b> .....	<b>5</b>
<b>6</b>	<b>DEFINITIONS</b> .....	<b>5</b>
<b>7</b>	<b>REFERENCES</b> .....	<b>5</b>
<b>8</b>	<b>TRADEMARKS</b> .....	<b>5</b>
<b>9</b>	<b>INTRODUCTION</b> .....	<b>6</b>
9.1	Entellion .....	6
9.2	Scope .....	6
9.3	Battery Overview .....	6
<b>10</b>	<b>DESIGN SPECIFICATION</b> .....	<b>7</b>
10.1	Cell & Battery Specifications .....	7
10.2	Connection specification .....	8
10.3	Charging .....	8
10.4	Discharging .....	9
10.5	Storage .....	10
10.6	Life Expectancy .....	10
<b>11</b>	<b>SMART ELECTRONICS MODULE</b> .....	<b>11</b>
11.1	Block Diagram .....	11
11.2	Fuel-Gauge Electronics .....	11
11.3	SHA-1 Authentication .....	11
11.4	Protection Electronics .....	12
11.5	Passive Over-Current Protection .....	12
11.6	Electronics Module Current Consumption .....	12
<b>12</b>	<b>MECHANICAL SPECIFICATIONS</b> .....	<b>14</b>
12.1	Overview .....	14
12.2	Mechanical Drawing .....	14
12.3	Case Material .....	14
12.4	Weight .....	14
12.5	Label Details .....	15
12.6	Packaging .....	15
<b>13</b>	<b>ENVIRONMENTAL / SAFETY SPECIFICATIONS</b> .....	<b>16</b>

Document Title		Document ID	Version	Date
Technical Specification		1624B_TLS	0.4	10.02.16
Project Designation	Product	Customer		Page
1624B	CC1150 Battery	Various		3 / 23

13.1	Transportation .....	16
13.2	IEC 62133 .....	16
13.3	Battery Directive .....	16
13.4	Electromagnetic Compatibility (EMC) .....	16
13.5	Restriction of Hazardous Substances (RoHS) .....	16
13.6	Waste Electrical and Electronic Equipment (WEEE).....	16
13.7	REACH.....	16
13.8	CE Marking .....	17
<b>14</b>	<b>BATTERY PRODUCTION REQUIREMENTS .....</b>	<b>18</b>
14.1	Quality Management Systems .....	18
14.2	Traceability.....	18
14.3	Reliability.....	18
14.4	Warranty .....	18
<b>15</b>	<b>LITHIUM ION BATTERY GENERAL PRECAUTIONS.....</b>	<b>19</b>
15.1	Danger!.....	19
15.2	Warning! .....	20
15.3	Caution!.....	20
15.4	Recommendations to End Users .....	21
<b>16</b>	<b>ACCUTRONICS CONTACT DETAILS.....</b>	<b>23</b>

## 2 INDEX OF FIGURES

Figure 1 - CC1150 (Top) .....	6
Figure 2 - CC1150 (bottom) .....	6
Figure 3 - XCHG Operation.....	9
Figure 4 - CHG_INH Operation.....	9
Figure 5 - Battery Electronics Block Diagram.....	11
Figure 6 - Battery Dimensions .....	14
Figure 7 - Battery Label.....	15

## 3 INDEX OF TABLES

Table 1 - Document Revisions .....	4
Table 2 – Cell Specification Summary.....	7
Table 3 - Battery Specification Summary.....	7
Table 4 - Connector Pin-Out .....	8
Table 5 - Active Over-Current Protection Limits.....	12
Table 6 - Electronics Current Consumption.....	12

<b>Document Title</b> Technical Specification		<b>Document ID</b> 1624B_TLS	<b>Version</b> 0.4	<b>Date</b> 10.02.16
<b>Project Designation</b> 1624B	<b>Product</b> CC1150 Battery	<b>Customer</b> Various		<b>Page</b> 4 / 23

## 4 REVISIONS

Revisions to this document are recorded in Table 1. Most recent changes are shown at the top of the table.

Version	AN Ref.	Detail	Date	Initial
0.4	16-E019	Document updated to 2016 format. Section 3.5 – Storage Batteries now shipped at <30% RSOC (was 40%) to conform to “Addendum No. 3” to the ICAO Technical Instructions for the Safe Transport of Dangerous Goods by Air (2015 – 2016 Edition)	10.02.16	GAH
0.3		Production Release	18..03.15	NRO
0.2		Finalisation of initial release	09.03.15	NRO
0.1		Initial release for discussion	05.01.15	NRO

*Table 1 - Document Revisions*

Document Title		Document ID	Version	Date
Technical Specification		1624B_TLS	0.4	10.02.16
Project Designation	Product	Customer		Page
1624B	CC1150 Battery	Various		5 / 23

## 5 PROJECT & DOCUMENT

- Customer name 'Various' applies
- Accutronics project reference '1624B' applies
- Document ID '1624B\_TLS' applies

## 6 DEFINITIONS

°C	Degrees Celsius
A	Ampere
Ah	Ampere Hour
ABS	Acrylonitrile Butadiene Styrene
C	Capacity
CC	Constant Current
CV	Constant Voltage
EMC	Electro-Magnetic Compatibility
ESD	Electro Static Discharge
IEC	International Electrotechnical Commission
mA	milli-Ampere
mAh	milli-Ampere Hour
OEM	Original Equipment Manufacturer
Wh	Watt-Hour

## 7 REFERENCES

- [1] Panasonic UF553450Z Cell Data Sheet
- [2] Texas Instruments BQ27541-G1 Data Sheet, ref. SLUSAL6C

## 8 TRADEMARKS

ACCUTRONICS and ENTELLION are European Community registered trademarks of Accutronics Limited.

Document Title		Document ID	Version	Date
Technical Specification		1624B_TLS	0.4	10.02.16
Project Designation	Product	Customer		Page
1624B	CC1150 Battery	Various		6 / 23

## 9 INTRODUCTION

### 9.1 Entellion

The CC1150 battery is part of the Accutronics 'Entellion' range. Entellion products are smart, innovative portable power products, designed to meet the emerging needs of feature-laden devices in professional markets. Entellion combines our expertise in custom OEM battery products with our understanding of professional OEM requirements and market trends. Entellion products are available off the shelf and can also be customised for your application, getting you to market quickly and confidently.

### 9.2 Scope

This specification describes the physical, functional and electrical characteristics of the CC1150 rechargeable Lithium Ion 'mini' credit card battery. This specification is the master document that controls the internal specifications from Accutronics. Batteries produced will meet this specification.

### 9.3 Battery Overview

The battery consists of a single Lithium Ion rechargeable cell. Each battery has a nominal voltage of 3.7V and a typical capacity of 1150mAh.

Each battery includes a battery management module that provides fuel gauging and active protection. The fuel gauging is realised through the use of a Texas Instruments BQ27541-G1. The active protection is realised through the use of a Seiko S-8241 series IC and dual MOSFETs.

The BQ27541-G1 communicates with the system host over an I<sup>2</sup>C interface (HDQ communication is available on the CC1150HDQ product – please contact us to discuss). It uses an impedance tracking algorithm to provide information such as state of charge (%), run-time to empty (min), charge time to full (min), battery voltage (V), and battery temperature (°C). The S-8241 battery protection IC (in conjunction with dual MOSFETs) provides protection from over charge, over discharge, over current and short circuit. Additional passive over current protection (PTC devices) are fitted for redundancy.

The cell and electronics are housed in a two piece injection moulded case. The case parts are manufactured from ABS and meet the requirements of UL94V-0. The case colour is black. External electrical connection is via a seven way Tyco connector which also has a mechanical keyway. The battery meets the requirements of IEC 62133:2012 and is also CE marked. The battery meets all current transportation regulations.



Figure 1 - CC1150 (Top)



Figure 2 - CC1150 (bottom)

Document Title Technical Specification		Document ID 1624B_TLS	Version 0.4	Date 10.02.16
Project Designation 1624B	Product CC1150 Battery	Customer Various		Page 7 / 23

## 10 DESIGN SPECIFICATION

### 10.1 Cell & Battery Specifications

#### 10.1.1 Cell Level Specification

Parameter	Value	Notes
Technology	Rechargeable Lithium Ion	Cell is prismatic in construction
Manufacturer	Panasonic	
Manufacturer Model Number	UF553450Z	1200mAh (0.2C typ) 1150mAh (0.2C min)
UL File Number	BBCV2.MH12383	
IEC CB Certificate Number	NL-32180 (4th August 2014)	Cell certified to IEC62133:2012

Table 2 – Cell Specification Summary

#### 10.1.2 Battery Level Specification

Parameter	Value	Notes
Technology / Configuration	Lithium Ion / 1S1P	
Nominal Voltage	3.7V	Average voltage during a 0.2C discharge at +20°C
Nominal Capacity	1150mAh	Based on 4.2V 0.5C charge at +20°C, followed by a 0.2C discharge to 3.0V at +20°C
Minimum Capacity	1093mAh	
Energy Rating	4.2Wh	Based on Nominal Voltage multiplied by Nominal Capacity
Charge Temperature Range	0°C to +45°C	Battery ambient temperature
Charge Voltage	4.20V	Charger voltage regulation should be better than ±1%
Maximum Charge Current	1093mA	547mA (0.5C) to 852mA (0.78C) recommended
Discharge Temp Range	-10°C to +50°C	See section 10.4
Maximum Discharge Current	2000mA	See section 10.4
Storage Temperatures	12 months: -20°C to +20°C	These are recommended storage temperatures. See section 10.5
	3 months: -20°C to +45°C	
	1 month: -20°C to +60°C	

Table 3 - Battery Specification Summary

Document Title		Document ID	Version	Date
Technical Specification		1624B_TLS	0.4	10.02.16
Project Designation	Product	Customer		Page
1624B	CC1150 Battery	Various		8 / 23

## 10.2 Connection specification

The battery is fitted with a 7-way, 2mm pitch Tyco connector (part number 1827684-1). The recommended mating part is a Tyco 1827654-1 or 1827654-2 (1827654-1 can be purchased from Accutronics under part number CO3081). The battery connector interface is defined in Table 4.

Terminal	Legend	Description
1	(BAT+)	Positive side of battery
2	(N/C)	This pin is reserved for optional HDQ communication. DO NOT connect to this pin when using I <sup>2</sup> C
Mechanical Keyway		Mechanical keyway between terminals 2 and 3
3	(SCL)	I <sup>2</sup> C clock. Internally a 1M $\Omega$ resistor is connected between (SCL) & (BAT-)
4	(SDA)	I <sup>2</sup> C Data. Internally a 1M $\Omega$ resistor is connected between (SDA) & (BAT-)
5	(NTC)	10K $\Omega$ NTC connected between (NTC) and (BAT-)
6	(BAT-)	Negative side of battery
7	(BAT-)	Negative side of battery

*Table 4 - Connector Pin-Out*

The I<sup>2</sup>C clock and data lines require pull-ups to system logic voltage in the customer equipment, NOT the battery voltage. Typically a 15K $\Omega$  pull-up resistor is used, but refer to the I<sup>2</sup>C specification for additional information.

## 10.3 Charging

It is recommended that a CVCC charger is used to charge the battery. The maximum charge voltage for the battery is 4.20V and the maximum recommended charge current is 852mA. The allowable temperature for battery charging is 0°C to +45°C. The host device should make reference to the appropriate flags set by the BQ27541-G1 and suspend charging if any of the following Flags() are set:

- OTC = Over-Temperature in Charge, this bit is set if the temperature exceeds +45°C during charge, reset when the temperature falls below +40°C.
- FC = Full-charged condition reached. The FC bit is set when StateOfCharge() is 100% and cleared when StateOfCharge() is less than 98%.
- TCA = Full-charged condition reached. The TCA bit is set when StateOfCharge() is 100% and cleared when StateOfCharge() is less than 95%.
- XCHG = Charge Suspend Alert indicates the temperature is outside the range -5°C to +45°C with 2°C of hysteresis.



Document Title Technical Specification		Document ID 1624B_TLS	Version 0.4	Date 10.02.16
Project Designation 1624B	Product CC1150 Battery	Customer Various		Page 9 / 23

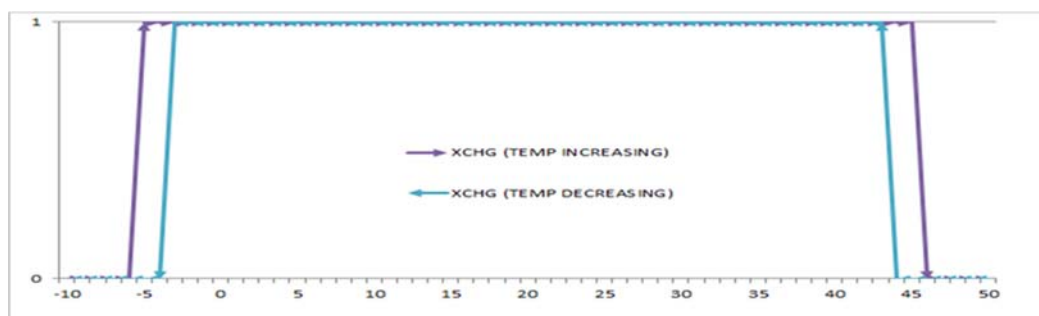

Figure 3 - XCHG Operation

- CHG\_INH = Charge Inhibit indicates the temperature is outside the range that charging should be allowed to start. The recommended range for charging to start is range 0°C to +40°C with 2°C of hysteresis.

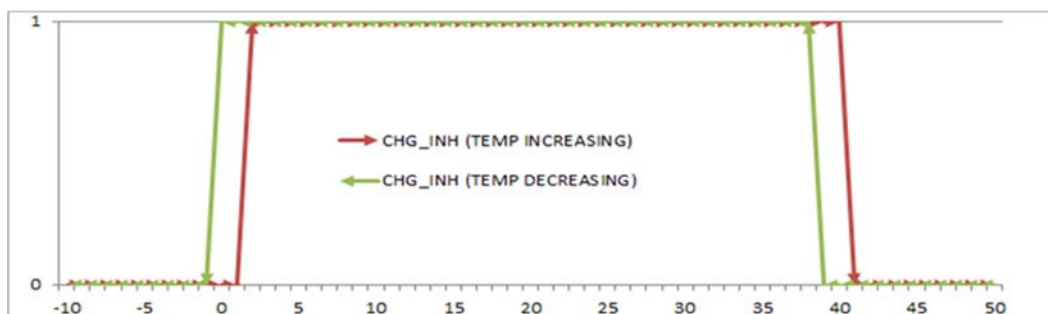

Figure 4 - CHG\_INH Operation

### 10.3.1 Charge Termination Detection

The bq27541-G1 detects charge termination when the following conditions are met:

- AverageCurrent() is < 61mA for more than 80seconds
- During the same 80seconds, the accumulated change in capacity >0.00625mAh
- Charging voltage > 4100mV

When this occurs, the [CHG] bit of Flags() is cleared and RemainingCapacity() is set equal to FullChargeCapacity()

## 10.4 Discharging

The battery is capable of being discharged at a maximum of 2000mA without the protection circuit activating or the cell being damaged. Discharge performance depends on initial state of charge, discharge rate, temperature, soak time, battery age and level of thermal insulation around the battery. Discharge at high currents and/or low temperatures will severely reduce the delivered energy from the battery and customers should perform empirical testing to determine suitability in their application.

The host device should make reference to the appropriate flags set by the BQ27541-G1 and suspend discharging if the following bit is set in the BQ27541-G1 Flags() register:

Document Title		Document ID	Version	Date
Technical Specification		1624B_TLS	0.4	10.02.16
Project Designation	Product	Customer		Page
1624B	CC1150 Battery	Various		10 / 23

- OTD = Over-Temperature in Discharge condition is detected. True when the temperature exceeds +60°C, reset when the temperature falls below +55°C

The following bits in the BQ27541-G1 Flags() register are used to indicate that the battery capacity is nearly depleted:

- SOC1 = State-of-Charge-Threshold 1, this bit is set when the remaining capacity of the battery reaches 115mAh and reset when the capacity exceeds 173mAh
- SOCF = State-of-Charge-Threshold Final, this bit is set when the remaining capacity of the battery reaches 12mAh and reset when the capacity exceeds 58mAh

## 10.5 Storage

The battery is capable of being safely stored & transported over a temperature range of -20°C to +60°C. OEMs and end users should avoid storing the batteries for prolonged periods towards the high end of this range as it will permanently degrade the life of the battery. Batteries should ideally be stored in a partially charged state and in an environment with low humidity free from corrosive gas within a temperature range of -20°C to +20°C.

Batteries are shipped from Accutronics with ≤30% residual capacity which will provide a minimum of 12 months useable residual capacity if stored at or below room temperature. If the batteries are stored at a temperature higher or if the storage period exceeds 12 months then the residual capacity may be depleted and the internal protection electronics will enter a hibernate mode to protect the internal cells from damage caused by over discharge. Charging the battery will automatically re-wake the battery.

## 10.6 Life Expectancy

### 10.6.1 Cycle Life

Each new battery is expected to deliver a minimum of 80% of its minimum rated capacity after 300 cycles where the charge and discharge phases are as described in table Table 3.

### 10.6.2 Cell Life

This technical specification details the environmental temperature limits for storage, charge and discharge that the battery may safely tolerate.

The extremes of temperature in this specification are not limits that the battery can be expected to operate at continuously and regular operation at extremes of temperature (especially elevated temperature) will degrade battery life and may result in the battery failing to deliver the specified capacity before the cycle life requirement or the warranty period have been reached. In addition, the life of a Lithium ion battery is degraded if it maintained at high states of charge (especially at elevated temperatures) and experiences infrequent discharge activity.

If the application requires that the battery be maintained at high state of charge at elevated temperature then Accutronics can suggest modifications to the charge regime to promote improved battery life. Such modifications usually result in a reduction in initial battery capacity which must be catered for in runtime requirements. Batteries which are returned within the warranty period and which exhibit poor performance due to regular exposure to elevated temperatures will not be accepted by Accutronics as valid warranty returns.

### 10.6.3 Fuel Gauge Accuracy

The fuel gauge within the battery uses both coulomb counting and the impedance tracking algorithms to calculate remaining battery capacity. Applications that operate full charge and discharge cycles or applications

Document Title		Document ID	Version	Date
Technical Specification		1624B_TLS	0.4	10.02.16
Project Designation	Product	Customer		Page
1624B	CC1150 Battery	Various		11 / 23

that have significant rest periods between charge and discharge allow the fuel gauge to make regular and accurate adjustments to the capacity prediction. Applications which keep the battery in high state of charge and have little or no discharge or rest activity may not allow the fuel gauge to update its battery capacity predictions and as a result, battery fuel gauge information may become unreliable.

As part of the development and verification process the customer should satisfy themselves that the battery fuel gauge provides sufficient accuracy for their application requirements, either through empirical testing in the device or by providing Accutronics with specific use cases that can be verified as part of the battery verification process. Batteries which are returned within the warranty period and that exhibit poor fuel gauge accuracy will not be accepted by Accutronics as valid warranty returns unless they have had their use cases verified.

## 11 SMART ELECTRONICS MODULE

### 11.1 Block Diagram

The battery block diagram is shown in Figure 5.

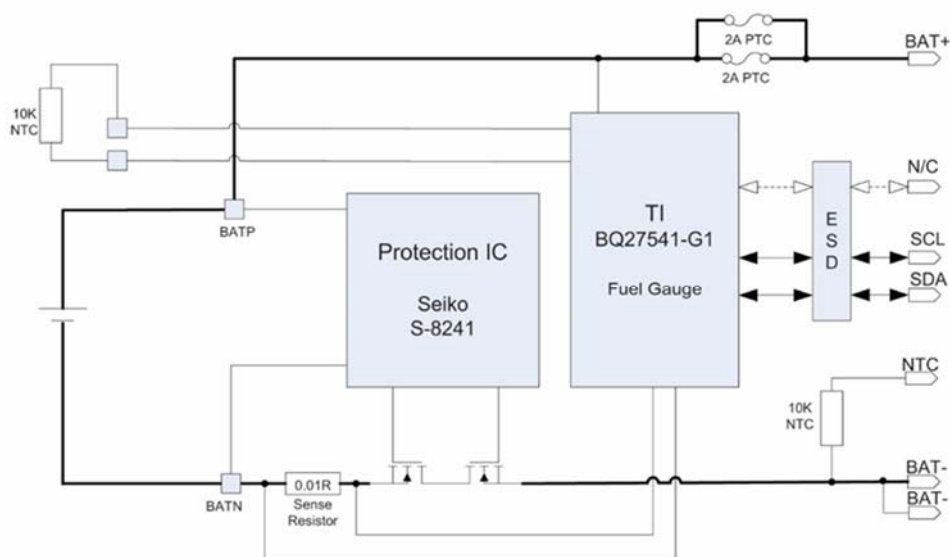

Figure 5 - Battery Electronics Block Diagram

### 11.2 Fuel-Gauge Electronics

The battery electronics include a Texas Instruments BQ27541-G1 single cell Li-Ion battery manager with impedance track fuel gauge technology. The fuel gauge communicates with the host using a two wire I<sup>2</sup>C interface (HDQ interface is available as an option – please contact Accutronics to discuss).

For detailed information regarding the operation of the BQ27541-G1, refer to the Texas Instruments website.

### 11.3 SHA-1 Authentication

SHA-1 authentication is available on custom versions of the battery. Please contact us to discuss.

Document Title		Document ID	Version	Date
Technical Specification		1624B_TLS	0.4	10.02.16
Project Designation	Product	Customer		Page
1624B	CC1150 Battery	Various		12 / 23

## 11.4 Protection Electronics

Active safety protection is based around the Seiko S-8241 series IC and provides over charge, over discharge, over current and short circuit protection via a pair of MOSFETs which may be switched off to prevent either charge and / or discharge from occurring.

### 11.4.1 Over-Charge Protection

The protection circuit will prevent the battery from charging at a voltage of 4.35V. Once the battery voltage is lowered to 4.15V, e.g. by discharging, it will allow charging again. The over-charge detection delay time is typically 125mS.

### 11.4.2 Over-Discharge Protection

The protection circuit will prevent the battery from being further discharged once the cell voltage reaches 2.10V or less. Once the cell voltage has reached 2.20V, e.g. by charging, it will allow the battery to discharge again. The over-discharge detection delay time is typically 31mS.

### 11.4.3 Over-Current Protection

The active over-current protection (see Table 5 ) is used to detect abnormal current during discharge.

Condition	Trip Current (min/typ/max)	Delay (min/typ/max)
Over-Current Level 1	3.2A / 4.76A / 6.06A	11.2ms / 16ms / 20.8ms
Over-Current Level 2	20A / 28.5A / 35A	1.4ms / 2ms / 2.6ms
Load Short Circuit	Not Applicable	--- / 10us / 50us

Table 5 - Active Over-Current Protection Limits

## 11.5 Passive Over-Current Protection

The battery is fitted with two PTC resettable fuses with a hold current of 2A (at +23°C) connected in parallel to provide passive over-current protection.

## 11.6 Electronics Module Current Consumption

The fuel gauge has several modes of operation that effect the battery electronics current consumption; these modes are shown in Table 6.

Electronics Operating Mode	Current Consumption
Normal	<150uA
Fuel Gauge in SLEEP Mode	<65uA
Fuel gauge in FULLSLEEP mode	<25uA
Fuel gauge in HIBERNATE mode	<10uA

Table 6 - Electronics Current Consumption

In 'Normal' operating mode, the electronics is fully operational and the fuel gauge updates its parameters every 1 second. The BQ27541-G1 will enter SLEEP low power mode when the BQ27541-G1 AverageCurrent() is less than 10mA. SLEEP mode is exited when the AverageCurrent() exceeds 10mA OR the current measured by SRN/SRP through the sense resistor is more than 100mA. If the FULLSLEEP bit is set in the Control Status register when the BQ27541-G1 is in SLEEP mode, the FULLSLEEP mode will be entered. The BQ27541-G1 exits FULLSLEEP

<b>Document Title</b> Technical Specification		<b>Document ID</b> 1624B_TLS	<b>Version</b> 0.4	<b>Date</b> 10.02.16
<b>Project Designation</b> 1624B	<b>Product</b> CC1150 Battery	<b>Customer</b> Various		<b>Page</b> 13 / 23

if any communication occurs OR the current measured by SRN/SRP through the sense resistor is more than 100mA. In SLEEP and FULLSLEEP, the BQ27541-G1 data is updated every 20 seconds.

HIBERNATE mode can be entered from SLEEP mode when all of the following is true:

- The cell is in a relaxed state
- AverageCurrent() is less than 8mA
- Voltage() is less than 2400mV OR HIBERNATE bit in the CONTROL\_STATUS register is set

HIBERNATE mode is exited if any communication occurs.

[Note, It is not recommended to charge/discharge in HIBERNATE mode as changes in charge status are not measured]. For a full description of the BQ27541-G1 power modes, see the device datasheet.

Document Title		Document ID	Version	Date
Technical Specification		1624B_TLS	0.4	10.02.16
Project Designation	Product	Customer		Page
1624B	CC1150 Battery	Various		14 / 23

## 12 MECHANICAL SPECIFICATIONS

### 12.1 Overview

The cell, electronics and connector are housed in an injection moulded plastic case which measures 54.0mm x 54.0mm x 9.1mm. A female latch feature is incorporated into the end of the battery opposite the connector. This feature can be used to retain the battery if an appropriate male feature is designed into the customers host equipment. A CAD model of the battery is available.

### 12.2 Mechanical Drawing

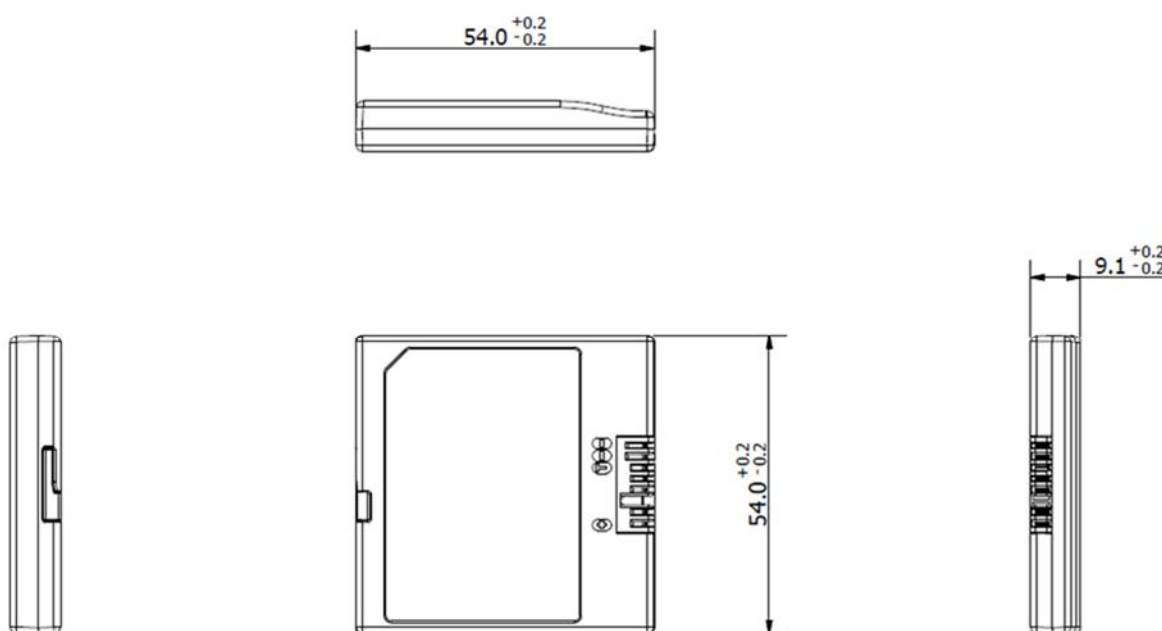

Figure 6 - Battery Dimensions

### 12.3 Case Material

The battery case is manufactured from ABS and meets the requirements of UL94V-0 (at the minimum wall thickness). The case colour is black. Accutronics can provide the battery in custom colours if required by the OEM. Please contact us to discuss.

### 12.4 Weight

The battery has a typical weight of 37g.

<b>Document Title</b> Technical Specification		<b>Document ID</b> 1624B_TLS	<b>Version</b> 0.4	<b>Date</b> 10.02.16
<b>Project Designation</b> 1624B	<b>Product</b> CC1150 Battery	<b>Customer</b> Various		<b>Page</b> 15 / 23

## 12.5 Label Details

The battery is fitted with a single metalized polyester label. The label is coloured silver. The text and symbols are printed in black. An example of the label is shown below. Accutronics can provide a custom labelled version of the battery if required by the OEM. Please contact us to discuss.



*Figure 7 - Battery Label*

In this example, XXXXX is a serial number from 00001 to 99999. YY is the year of manufacture and WW is the week of manufacture.

## 12.6 Packaging

The battery is individually packed in a re-sealable clear plastic bag. Batteries are then appropriately packed for bulk shipment. Accutronics can provide custom packaging for the battery if required by the OEM. Please contact us to discuss.

Document Title		Document ID	Version	Date
Technical Specification		1624B_TLS	0.4	10.02.16
Project Designation	Product	Customer		Page
1624B	CC1150 Battery	Various		16 / 23

## 13 ENVIRONMENTAL / SAFETY SPECIFICATIONS

### 13.1 Transportation

The battery meets the requirements of testing specified in the Recommendations on the Transport of Dangerous Goods, Manual of Tests and Criteria (ST/SG/AC.10.11/Rev5).

### 13.2 IEC 62133

The battery meets the requirements of IEC62133:2012 (Secondary cells and batteries containing alkaline or other non-acid electrolytes – Safety requirements for portable sealed secondary cells, and for batteries made from them, for use in portable applications). A CB Test Certificate is available upon request.

### 13.3 Battery Directive

The battery meets the requirements of Directive 2006/66/EC of the European Parliament and of the Council of 6 of September 2006 on batteries and accumulators and waste batteries and accumulators and repealing Directive 91/157/EEC.

### 13.4 Electromagnetic Compatibility (EMC)

The battery meets the requirements of the EMC Directive 2004/108/EC. Compliance has been demonstrated by conformance to the following standards which have been listed in the Official Journal of the European Communities:

- EN 55022:2006 +A1: 2007 - Radiated Emissions
- EN61000-4-2: 1995 +A1:1999 +A2 – Electrostatic Discharge
- EN61000-4-3:1996 +A1:1998 - Radiated Immunity

### 13.5 Restriction of Hazardous Substances (RoHS)

No RoHS banned materials are used (as per the Europa Chemical Candidate List) in the manufacture of the battery. The battery meets the requirements of the RoHS2 Directive 2011/65/EU and original RoHS Directive 2002/95/EC.

### 13.6 Waste Electrical and Electronic Equipment (WEEE)

The battery is compliant with the Waste Electronic & Electrical Equipment Regulations 2006 (UK) and meets the requirements of the Waste Electronic & Electrical Equipment Directive (2002/96/EC, Amendment 2003/108/EC and Recast 2012/19/EU).

### 13.7 REACH

The battery is compliant with the Registration, Evaluation, Authorisation and Restriction of Chemicals (REACH) - EU directive 1907/2006. No substances as per the European chemical Candidate List are present in the battery or used during its manufacture.



<b>Document Title</b> Technical Specification		<b>Document ID</b> 1624B_TLS	<b>Version</b> 0.4	<b>Date</b> 10.02.16
<b>Project Designation</b> 1624B	<b>Product</b> CC1150 Battery	<b>Customer</b> Various		<b>Page</b> 17 / 23

### 13.8 CE Marking

Compliance with the necessary directives for this type of device - EMC (section 13.4), RoHS and RoHS2 (section 13.5) permit the battery to be CE Marked.

<b>Document Title</b> Technical Specification		<b>Document ID</b> 1624B_TLS	<b>Version</b> 0.4	<b>Date</b> 10.02.16
<b>Project Designation</b> 1624B	<b>Product</b> CC1150 Battery	<b>Customer</b> Various		<b>Page</b> 18 / 23

## 14 BATTERY PRODUCTION REQUIREMENTS

### 14.1 Quality Management Systems

The battery manufacturer is certified to a recognised Quality Management System standard (ISO9001:2008 and ISO13485:2003 apply) for the design, manufacture, test and sale of battery products.

### 14.2 Traceability

Accutronics retain a list of the serial numbers of batteries built during manufacturing batches. This information is retained for a minimum of ten years.

### 14.3 Reliability

The battery is designed and manufactured with the intention that the in-warranty (one year) failure rate will be better than 100ppm (0.01% failure / 99.99% pass).

### 14.4 Warranty

A high quality standard is maintained by Accutronics Limited. All products are warranted against defects in design, workmanship, material and construction. The warranty period is 12 months from the date of shipment from Accutronics as indicated by Accutronics YYWW date code on the battery label (see section 12.5 for details).

Document Title		Document ID	Version	Date
Technical Specification		1624B_TLS	0.4	10.02.16
Project Designation	Product	Customer		Page
1624B	CC1150 Battery	Various		19 / 23

## 15 LITHIUM ION BATTERY GENERAL PRECAUTIONS

### 15.1 Danger!

- Do not disassemble or modify the battery. The battery is equipped with built-in safety/protection features. Should these features be disabled, the battery can leak electrolyte, overheat, emit smoke, burst and/or ignite.
- Do not connect the positive (+) and negative (-) terminals with a metal object such as wire. Do not transport or store the battery together with metal objects such as necklaces, hair pins, etc. Otherwise, short-circuiting will occur, over-current will flow, causing the battery to leak electrolyte, overheat, emit smoke, burst and/or ignite, or the metal object such as wire, necklace or hair pin can generate heat.
- Do not discard the battery into fire or heat it. Otherwise, its insulation can melt down, its gas release vent or safety features will be damaged and/or its electrolyte can ignite, possibly leading to electrolyte leakage, overheating, smoke emission, bursting and/or ignition on it.
- Do not use or leave the battery near a heat source such as a fire or a heater (+80°C or higher). If the resin separator should be damaged owing to overheating, internal short-circuiting may occur to the battery, possibly leading to electrolyte leakage, smoke emission, bursting and/or ignition of the battery.
- Do not immerse the battery in water or seawater and do not allow it to get wet. Otherwise, the protective features in it can be damaged, it can be charged with extremely high current and voltage, abnormal chemical reactions may occur in it, possibly leading to electrolyte leakage, smoke emission, bursting and/or ignition.
- Do not recharge the battery near fire or in extremely hot weather. Otherwise, hot temperatures can trigger its built-in protective features, inhibiting recharging, or can damage the built-in protective features, causing it to be charged with an extremely high current and voltage and, as a result, abnormal chemical reactions can occur in it, possibly leading to electrolyte leakage, overheating, smoke emission, bursting and/or ignition.
- To recharge the battery use the battery charger specifically designed for the purpose and observe the recharging conditions specified by ACCUTRONICS. A recharging operation under non-conforming recharging conditions (higher temperature and larger voltage/current than specified, modified battery charger, etc.) can cause the battery to be overcharged, or charged with extremely high current, abnormal chemical reaction can occur in it, possibly leading to electrolyte leakage, overheating, smoke emission, bursting and/or ignition.
- Do not pierce the battery with a nail or other sharp objects, strike it with a hammer, or step on it, otherwise, the battery will become damaged and deformed, internal short-circuiting can occur, possibly leading to electrolyte leakage, overheating, smoke emission, bursting and/or ignition.
- Do not subject the battery to sudden mechanical shock. The impact might cause leakage, overheating, smoke emission, bursting and/or ignition. Also, if the protective feature in it becomes damaged, it could become charged with an extremely high current and voltage, abnormal chemical reactions can occur, which can lead to electrolyte leakage, overheating smoke emission, bursting and/or ignition.
- Do not use an apparently damaged or deformed battery. Otherwise, electrolyte leakage, overheating, smoke emission, bursting and/or ignition of the battery may occur.
- Do not directly solder the battery. Otherwise, heat can melt down its insulation, damage its gas release vent or safety features, possibly leading to electrolyte leakage, overheating, smoke emission, bursting and/or ignition.

Document Title		Document ID	Version	Date
Technical Specification		1624B_TLS	0.4	10.02.16
Project Designation	Product	Customer		Page
1624B	CC1150 Battery	Various		20 / 23

- Do not reverse the positive (+) and negative (-) terminals. Otherwise, during recharging, the battery will be reverse-charged, abnormal chemical reactions then may occur, or excessively high current can flow during discharging, leading to electrolyte leakage, overheating, smoke emission, bursting and/or ignition.
- The positive (+) and negative (-) terminals are arranged in a particular orientation. Do not force the connection if you cannot easily connect the battery terminals to the battery charger or other equipment. Confirm that the terminals are correctly oriented. Reversing the terminals will result in reverse-charging, possibly leading to electrolyte leakage, overheating, smoke emission, bursting and/or ignition of the battery.
- Do not connect the battery to an electrical outlet, vehicle cigarette lighter, etc. When subjected to large voltage, over-current can flow on the battery, possibly leading to electrolyte leakage, overheating, smoke emission, bursting and/or ignition.
- Do not use the battery for a purpose other than those specified. Otherwise, its guaranteed performance will be lost and/or its service life will be shortened. Depending on the equipment in which the battery is used, excessively high current can flow through battery, possibly damaging it and leading to electrolyte leakage, overheating, smoke emission, bursting and/or ignition.
- If the battery leaks and electrolyte gets into the eyes, do not rub them. Instead, rinse the eyes with clean running water and immediately seek medical attention. Otherwise, eye injury may result.

## 15.2 Warning!

- Do not use the battery in combination with primary batteries (such as dry-cell batteries) or batteries of different capacities or brands. Otherwise, the battery can be over-discharged during use or overcharged during recharging, abnormal chemical reactions may occur, possibly leading to electrolyte leakage, overheating, smoke emission, bursting and/or ignition.
- If recharging operation fails to complete even when a specified recharging time has elapsed, immediately stop further recharging. Otherwise, electrolyte leakage, overheating, smoke emission, bursting and/or ignition can occur.
- Do not put the battery into a microwave oven or pressurised container. Rapid heating or disrupted sealing can lead to electrolyte leakage, overheating, smoke emission, bursting and/or ignition.
- If electrolyte leaks from the battery or gives off a bad odour, remove it from any exposed flame. Otherwise, the leaking electrolyte may catch fire and the battery may emit smoke, burst or ignite.
- If the battery gives off an odour, generates heat, becomes discoloured or deformed, or in any way appears abnormal during use, recharging or storage, immediately remove it from the equipment or battery charger and stop using it. Otherwise, the problematic battery can develop electrolyte leakage, overheating, smoke emission, bursting and/or ignition.

## 15.3 Caution!

- Do not subject the battery to intense sunlight or hot temperatures, for example in a car during hot weather. Otherwise, electrolyte leakage, overheating and/or smoke emission can occur. Also, its guaranteed performance will be lost and/or its service life will be shortened.
- The battery incorporates built-in safety devices. Do not use it in a location where static electricity (greater than the manufacturer's guarantee) may be present. Otherwise, the safety devices can be damaged, possibly leading to electrolyte leakage, overheating, smoke emission, bursting and/or ignition.

Document Title		Document ID	Version	Date
Technical Specification		1624B_TLS	0.4	10.02.16
Project Designation	Product	Customer		Page
1624B	CC1150 Battery	Various		21 / 23

- The guaranteed recharging temperature range is 0°C to +45°C. A recharging operation outside this temperature range can lead to electrolyte leakage and/or overheating of the battery and may cause damage to it.
- If electrolyte leaking from the battery comes into contact with your skin or clothing, immediately wash it away with running water. Otherwise, skin inflammation can occur.
- Store the battery in a location where children cannot reach it. Also, make sure that a child does not take the battery out of the battery charger or equipment.
- Before use, study carefully these Precautions. For further information contact the nearest ACCUTRONICS distributor or representative. Retain the original product literature for future reference.
- For recharging procedures, refer to the Operation Manual of your battery charger.
- If you find rust, a bad odour, overheating and/or other irregularities when using the battery for the first time, return it to your supplier or vendor.

#### 15.4 Recommendations to End Users

The following represents a typical, but not exhaustive list of good advice to be provided by the equipment manufacturer to the end-user.

- Do not dismantle, open or shred secondary cells or batteries.
- Do not expose cells or batteries to heat or fire. Avoid storage in direct sunlight.
- Do not short-circuit a cell or a battery. Do not store cells or batteries haphazardly in a box or drawer where they may short-circuit each other or be short-circuited by other metal objects.
- Do not remove a cell or battery from its original packaging until required for use.
- Do not subject cells or batteries to mechanical shock.
- In the event of a cell leaking, do not allow the liquid to come in contact with the skin or eyes. If contact has been made, wash the affected area with copious amounts of water and seek medical advice.
- Do not use any charger other than that specifically provided for use with the equipment.
- Observe the plus (+) and minus (-) marks on the cell, battery and equipment and ensure correct use.
- Do not use any cell or battery which is not designed for use with the equipment.
- Do not mix cells of different manufacture, capacity, size or type within a device.
- Keep cells and batteries out of the reach of children.
- Seek medical advice immediately if material or content from a cell or a battery has been swallowed.
- Always purchase the correct cell or battery for the equipment.
- Keep cells and batteries clean and dry.
- Wipe the cell or battery terminals with a clean dry cloth if they become dirty.
- Secondary cells and batteries need to be charged before use. Always use the correct charger and refer to the manufacturer's instructions or equipment manual for proper charging instructions.
- Do not leave a battery on prolonged charge when not in use.

<b>Document Title</b> Technical Specification		<b>Document ID</b> 1624B_TLS	<b>Version</b> 0.4	<b>Date</b> 10.02.16
<b>Project Designation</b> 1624B	<b>Product</b> CC1150 Battery	<b>Customer</b> Various		<b>Page</b> 22 / 23

- After extended periods of storage, it may be necessary to charge and discharge the cells or batteries several times to obtain maximum performance.
- Secondary cells and batteries give their best performance when they are operated at normal room temperature (+20°C ± 5°C).
- Retain the original product literature for future reference.

Batteries must be recycled or disposed of properly. Follow local regulations and ordinances for the disposal of the batteries. Recycle facilities may not be available in all areas.

<b>Document Title</b> Technical Specification		<b>Document ID</b> 1624B_TLS	<b>Version</b> 0.4	<b>Date</b> 10.02.16
<b>Project Designation</b> 1624B	<b>Product</b> CC1150 Battery	<b>Customer</b> Various		<b>Page</b> 23 / 23

## 16 ACCUTRONICS CONTACT DETAILS

- Telephone                                   +44 (0) 1782 566622
- Email (Customer Services)           tech@accutronics.co.uk
- Email (Technical Support)           sales@accutronics.co.uk